





#### Technical data 1/2"

<b>Dimensions:</b> H70 x W45 x L59 mm	<b>Operating voltage:</b> 12 VDC
<b>Pressure/Flow:</b> 0.15 – 10 bar / 42 l/min.	<b>Coil:</b> Bistable
<b>Connection:</b> IN: 1/2" female thread OUT: 1/2" female thread	



#### Technical data 3/4"

<b>Dimensions:</b> H76 x W55 x L79 mm	<b>Operating voltage:</b> 12 VDC Bistable coil
<b>Pressure/Flow:</b> 0.15 – 10 bar / 92 l/min.	<b>Coil:</b> Bistable
<b>Connection:</b> IN: 3/4" female thread OUT: 3/4" female thread	

**CTM  
LYNG**

#### Testing the installation

Testing can be done in several ways, depending on what accessories are connected.

- With **Moisture Sensor**, see instructions for moisture sensor for how to simulate moisture.
- With **Master On/Off**, check that the water is turned on/off when the button is pressed.
- With **Timer**, check that the water turns off when the time expires.
- With **Motion Sensor**, check that the water turns off when the time since last movement expires.

CTM Lyng AS is Norway's leading manufacturer and supplier of security products for the home, assistive technology, energy efficiency, and light and heating control for all building types under the mKomfy®, mTouch®, Microsafe® and Centrol® brands. We distribute our products through wholesalers. We offer everything from product development to production and distribution. Our production facility in Vanvikan is equipped with some of the most advanced machinery in Europe.

**Verkstedvegen 19, 7125 Vanvikan, Norway**

**Tel: +47 72 83 16 11**  
**Email: [marked@ctmlyng.no](mailto:marked@ctmlyng.no)**

**For more information, visit us at**  
**[www.ctmlyng.com](http://www.ctmlyng.com)**

**Thank you for choosing a product from CTM Lyng AS**

**CTM  
LYNG**

#### Installation instructions

#### Solenoid Valve



**1/2" Solenoid Valve**

No. 5648513 / 6251629



**3/4" Solenoid Valve**

No. 5648511 / 6251649

The Solenoid Valve is a security product from CTM Lyng AS.

The valve controls the water supply for a dwelling, individual rooms and relevant consumer electronics/appliances.

The system is flexible, and can be expanded to accommodate different needs and security levels.

**The valve can be controlled with:**

**Valve Driver**

No. 5648522 / 6254372

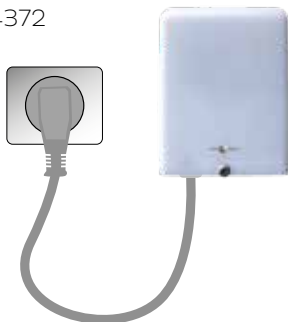

**Valve Driver with power adapter**

No. 5648523 / 6254371

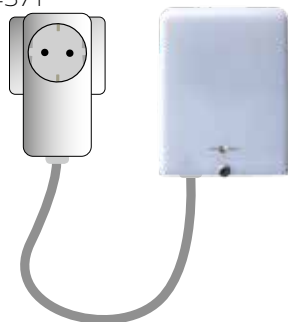

- The arrow on the valve indicates the direction of the water.
- It is supplied open.
- It is controlled with a 12 VDC pulse.
- The valve remains in the position in which it has been set until it receives a pulse with the opposite polarity.
- The valve does not change position if it is disconnected from the valve driver.
- Its position in the event of a power failure can be set on the valve driver, see instructions for valve driver.

**TIP:** Program all the units in a system before mounting. This will make it easier to test the equipment.

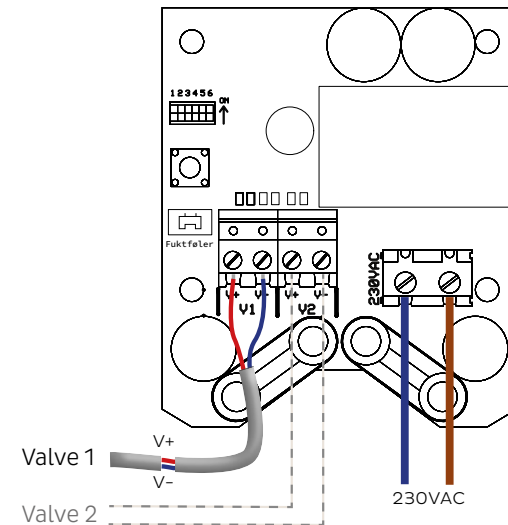

See instructions for valve driver for detailed information.



**Pairing components** (moisture sensor, control panel, motion sensor)

**Alternative 1** (To be carried out by authorised personnel only)

- Briefly press button SW1 in the valve driver. LED2 (yellow) will start to flash every 2 seconds. The valve driver is now in pairing mode for 60 seconds.
- NB: Operate the unit you want to pair with, see separate instructions.

**Alternative 2** (Can be carried out by anyone)

- Disconnect the power to the valve driver for 5 seconds by unplugging it and plugging it back in again. LED2 (yellow) will start to flash every 2 seconds. The valve driver is now in pairing mode for 60 seconds.
- NB: Operate the unit you want to pair with, see separate instructions. Disconnect the power to the valve driver for 5 seconds once more by unplugging it and plugging it back in again. This must be done within 1 minute of pairing.

#### Pairing HUB

(To be carried out by authorised personnel only)

- Activate pairing mode on mTouch HUB, see separate instructions.
- Hold button SW1 on the valve driver in for approx. 4 seconds until LED2 (yellow) and LED3 (red) light up simultaneously. The unit acknowledges that a pairing signal has been sent with 5 beeps.

#### DELETING PAIRED UNITS

To be carried out by authorised personnel only

NB: This deletes all the units that the valve driver is paired with.

- Hold button SW1 on the valve driver in for approx. 10 seconds until LED3 (red) starts to flash. NB: LED2 (yellow) and LED3 (red) will come on and go off again. Continue to hold the button in until the red LED starts to flash.
- When LED3 (red) flashes, release the button and LED3 (red) will acknowledge by flashing 5 times.

Deletion is complete.

**TIP:** To check how many units the valve driver is paired with, hold button SW1 in until LED2 (yellow) comes on steady. Then release the button. LED2 (yellow) will now flash a number of times = number of units it is paired with.

# CTM LYNG

#### Testing the installation

Testing can be done in several ways, depending on what accessories are connected.

- With **Moisture Sensor**, see instructions for moisture sensor for how to simulate moisture.
- With **Master On/Off**, check that the water is turned on/off when the button is pressed.
- With **Timer**, check that the water turns off when the time expires.
- With **Motion Sensor**, check that the water turns off when the time since last movement expires.

#### Technical data

**Dimensions:** HxWxD  
95 x 73 x 37 mm

**Operating voltage:**  
230 VAC +10/-20%

**RF:**  
868.100 MHz +5 dBm  
Compatible with "v2" equipment, see page 2

CTM Lyng AS is Norway's leading manufacturer and supplier of security products for the home, assistive technology, energy efficiency, and light and heating control for all building types under the mKomfy®, mTouch®, Microsafe® and Centrol® brands. We distribute our products through wholesalers.

We offer everything from product development to production and distribution. Our production facility in Vanvikan is equipped with some of the most advanced machinery in Europe.

**Verkstedvegen 19, 7125 Vanvikan, Norway**

**Tel: +47 72 83 16 11**  
**Email: [marked@ctmlyng.no](mailto:marked@ctmlyng.no)**

**For more information, visit us at**  
**[www.ctmlyng.com](http://www.ctmlyng.com)**

**Thank you for choosing a product from CTM Lyng AS**

# CTM LYNG

#### Installation and user instructions

For prod. week 38-2019 onwards

#### Valve Driver

No. 5648522 / 6254372

#### Valve Driver with power adapter

No. 5648523 / 6254371

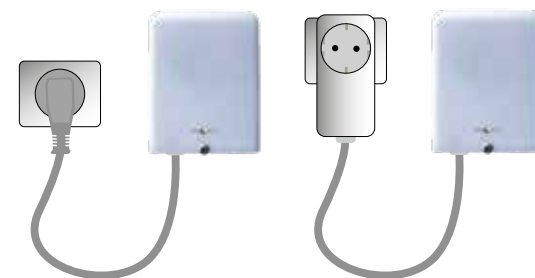

The Valve Driver is a security product from CTM Lyng AS.

The valve driver controls 1 or 2 valves simultaneously and can communicate wirelessly with up to 16 units.

**Compatible with**

- ½" and ¾" solenoid valves
- Moisture Sensor, wireless
- Motion Sensor, wireless
- Master On/Off, wireless
- Timer, wireless
- mTouch Economy Switch
- mTouch HUB



Look for products labelled "v2"

The system is flexible, and can be expanded to accommodate different needs and security levels.

The installation should be tested at least once a year, see *TESTING THE INSTALLATION*, page 6.

**MOTION SENSOR FUNCTION**

When the motion sensor detects movement, the valve turns the water on. Adjustable turn-off time: sets how long valve remains open after last detected movement. 1 min. – 4 hours.

**MOISTURE SENSOR FUNCTION**

When an external wireless moisture sensor detects moisture, the valve closes. To open the valve, turn off the alarm on the moisture sensor that was tripped.

**MASTER FUNCTION**

Closes and opens the valve when operated.

**The Master Switch overrides other units**

If a valve is turned off with Master On/Off, the same Master Switch has to be used to open the valve again. Also applies to all Mstikk sockets.

**TIP:** Program all the units in a system before installation. This will make it easier to test the equipment.

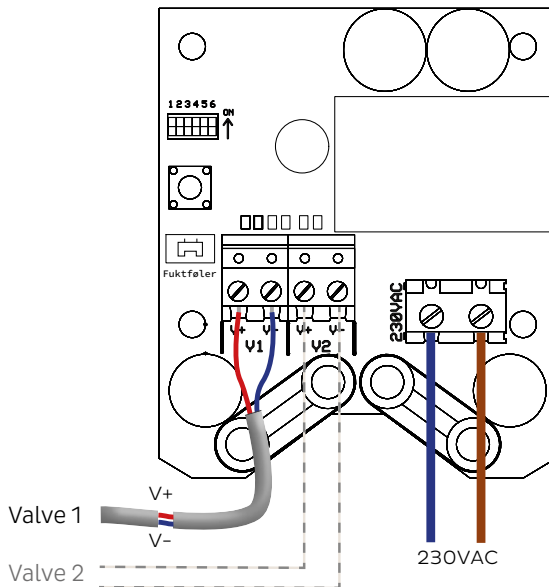

**INTERNAL MOISTURE SENSOR**

When the internal moisture sensor detects moisture (5 beeps every 10 seconds), the valve closes. To open the valve, turn the alarm off by pressing switch SW1 behind the front cover, or disconnect power to the valve driver for 5 seconds. If there is still moisture, the valve will be kept closed.

**VALVE INFORMATION**

- The arrow on the valve indicates the direction of the water.
- It is supplied open.
- It is controlled with a 12 VDC pulse.
- The valve remains in the position in which it has been set until it receives a pulse with the opposite polarity.
- The valve does not change position if it is disconnected from the valve driver. Its position in the event of a power failure can be set with DipSW (page 4).

DipSW	Factory	Function
1	OFF	ON*: Closes the valve if there is a power failure. OFF: Opens the valve if there is a power failure.
2	OFF	ON*: The valve does not change position in the event of a power failure. OFF: Follows DipSW 1.
3	OFF	ON: Test – Opens and closes every 5 seconds.
4	ON	ON: Jog function – Opens/closes the valve every 2 days.
5	OFF	ON: Emergency opening – Always open.
6		Not in use

\*When DipSW 1 and 2 are ON, DipSW 2 has top priority

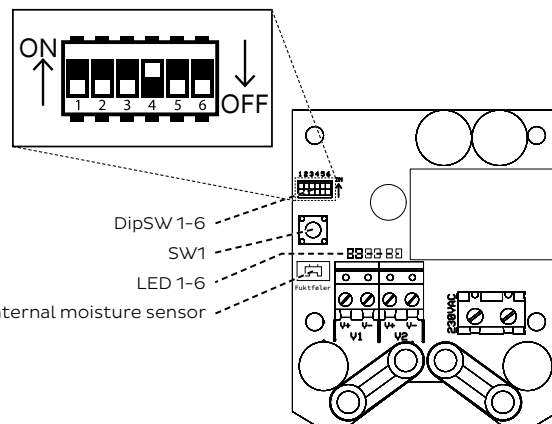

LED1	Green	Power (normal operation – 1 flash every second)
LED2	Yellow	Indicates pairing mode / number of paired units
LED3	Red	Indicates when valve is closed / internal alarm
LED4	Blue	Flashes briefly for radio communication
LED5	Green	Open pulse to valve
LED6	Red	Close pulse to valve

**TESTING THE VALVE AND DRIVER**

To be carried out by authorised personnel only

1. Open the tap halfway.
2. Set DipSW 3 to ON.
3. The valve will switch to being open/closed for 5 seconds.
4. Set DipSW 3 to OFF.

Testing is complete.

## PAIRING

Program the moisture sensor to communicate with one or more units.

### Alternative 1 (To be carried out by authorised personnel only)

1. Briefly press the button (SW1 in the socket/valve driver). The amber LED will start to flash every 2 seconds. The unit is now in pairing mode for 60 seconds.
2. Hold the button on the moisture sensor (SW1) in and insert the battery. The moisture sensor will beep twice to acknowledge that the battery has been inserted. Continue to hold the button in until the moisture sensor beeps three times. The units are now paired.

### Alternative 2 (Can be carried out by anyone)

1. Disconnect the power to the socket/valve driver by removing the fuse circuit/plug and putting it back again. The amber LED will start to flash every 2 seconds. The unit is now in pairing mode for 60 seconds.
2. Hold the button on the moisture sensor (SW1) in and insert the battery. The moisture sensor will beep twice to acknowledge that the battery has been inserted. Continue to hold the button in until the moisture sensor beeps three times. The units are now paired.
3. Disconnect the power to the socket/valve driver once more by removing the fuse circuit/plug and putting it back again. This saves the pairing. This must be done within 1 minute of pairing.

## TESTING COMMUNICATION

To test communication between the moisture sensor and valve driver/socket, briefly press the button (SW1) on the moisture sensor several times. The blue LED in the valve driver/socket should flash once for every press of the button.

## TESTING/FUNCTION TESTING THE MOISTURE SENSOR

1. Open the tap halfway.
2. Moisture can be simulated by short-circuiting two of the moisture sensor pins as shown on page 3. This can be done with a screw, another metal object or a damp cloth. The valve should then shut off the water supply.
3. To re-open the valve, reset the alarm by briefly pressing the Moisture Sensor's reset button (SW1).
4. Repeat for all moisture sensors in the system (to check how many moisture sensors there are, see page 5 of the *Installation and User Instructions for the Valve Driver* under Tip).

# CTM LYNG

## ANNUAL END USER TEST

The system owner/user must familiarise themselves with the accompanying Installation and User Instructions at installation, and is under an obligation to test that installed equipment shuts off the water supply as required in the Norwegian Insurance Approval Board (FG) test.

Function testing must be performed at least twice a year in accordance with the Installation and User Instructions for Moisture Sensors, On/Off Switches, Timers and Motion Sensors.

## Technical data

<b>Dimensions:</b> HxD 24 x 58 mm	<b>Battery:</b> 1x CR2450
<b>RF:</b> 868.100 MHz +5 dBm Compatible with "v2" equipment, see page 2	<b>Battery life:</b> Up to 4 years

CTM Lyng AS is Norway's leading manufacturer and supplier of security products for the home, assistive technology, energy efficiency, and light and heating control for all building types under the mKomfy®, mTouch®, Microsafe® and Centrol® brands.

We distribute our products through wholesalers.

We offer everything from product development to production and distribution. Our production facility in Vanvikan is equipped with some of the most advanced machinery in Europe.

**Verkstedvegen 19, 7125 Vanvikan, Norway**

**Tel: +47 72 83 16 11**  
**Email: [marked@ctmlyng.no](mailto:marked@ctmlyng.no)**

**For more information, visit us at**  
**[www.ctmlyng.com](http://www.ctmlyng.com)**

**Thank you for choosing a product from CTM Lyng AS**

# CTM LYNG

0320 Art. No.: 12607\_EN

## Installation and User instructions

For products made after week 16-2019

## Moisture Sensor, wireless

No. 5648535 / 6251608



The Moisture Sensor is a security product from CTM Lyng AS.

The moisture sensor closes the valve when it detects moisture, and cuts the power supply to sockets it is paired with.

The moisture sensor is mounted where moisture is expected.

When the battery is low, the moisture sensor will beep twice and the red LED (LED1) will flash every 5 minutes in addition to the LED flashing every 10 seconds.

**Compatible with**

- External Moisture Sensor 1 m
- Valve Driver and Valve Driver with power adapter
- All Mstikk sockets
- mTouch HUB



Look for products labelled "v2"

The system is flexible, and can be expanded to accommodate different needs and security levels.

**MOISTURE SENSOR FUNCTION**

When the moisture sensor detects moisture, it closes the valve and turns off the sockets it is paired with.

The moisture sensor sounds the alarm with three beeps and flashes every 10 seconds for 90 seconds. It will then beep and flash once every minute until it is reset by pressing the reset button.

**MOISTURE DETECTION**

If the moisture alarm is tripped, the moisture sensor will lock valves and sockets in the off position, and can only be re-opened by resetting the alarm on the moisture sensor that was tripped.

NB: The moisture sensor must be completely dry before the alarm can be reset. Dry it with a cloth or remove the battery and put to dry.

**NB:** Carry out pairing and test the moisture sensor before mounting. See page 5.

Mount the Moisture Sensor where moisture is expected to be detected.

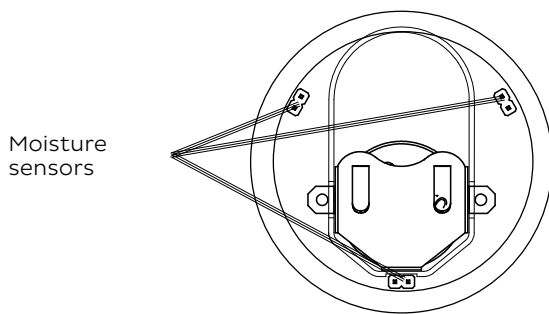

Secure the backplate with tape or the screws provided.

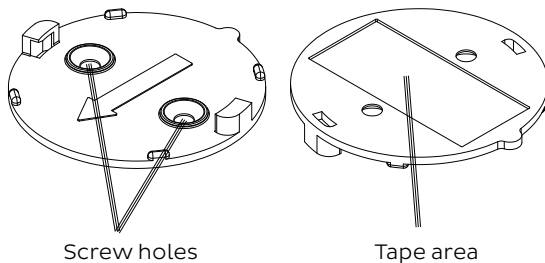

Mount with the arrow on the backplate towards the battery holder in the moisture sensor. Place the moisture sensor on the backplate and twist on clockwise.

**TIP:** Program all the units in a system before mounting. This will make it easier to test the equipment.

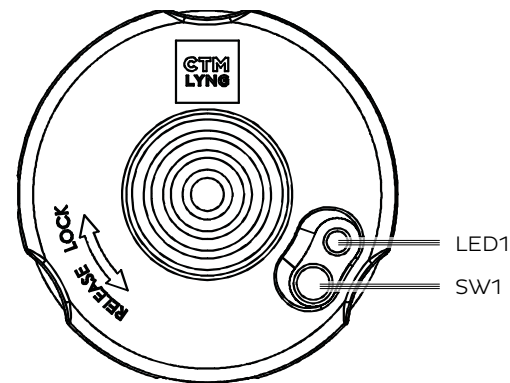

SW1		Programming/ reset button
LED1	Red	Alarm

**ACCESSORIES**

Accessories such as the **external moisture sensor** and **moisture sensor strip** connect to the moisture sensor at the terminal.

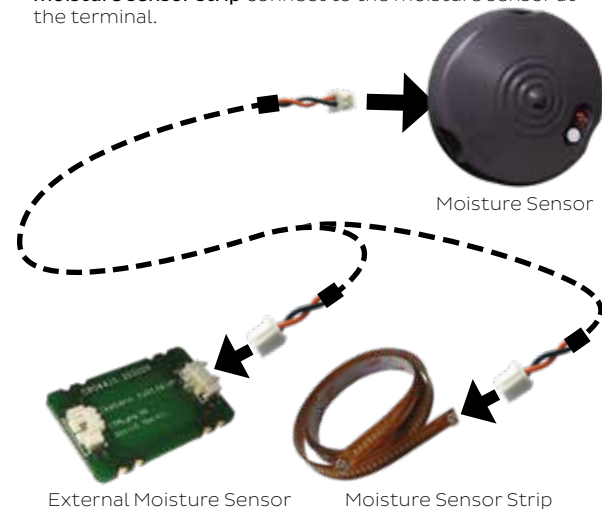

When the moisture sensor detects moisture, it closes the valve and sounds the alarm with three beeps and LED1 flashing every 10 seconds. After a minute and a half, it switches to beeping once and LED1 flashing every 10 seconds.

If the moisture disappears, the alarm will beep once and LED1 will flash every minute until the button is pressed. Otherwise, dry the sensor with a cloth. Press button SW1 to turn off. Remove the battery and put to dry.

To open the valve again, turn off the alarm with a quick press on the button (SW1) on the unit that was tripped.

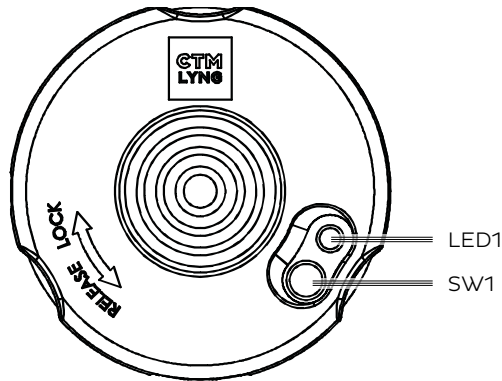

**CTM  
LYNG**

0320 Art. No.: 12132\_EN

**Technical data**

**Type:**  
Moisture Sensor 1 m cable  
**Recommended max. length:**  
5 sensors / 5 metres

CTM Lyng AS is Norway's leading manufacturer and supplier of security products for the home, assistive technology, energy efficiency, and light and heating control for all building types under the mKomfy®, mTouch®, Microsafe® and Centrol® brands. We distribute our products through wholesalers. We offer everything from product development to production and distribution. Our production facility in Vanvikan is equipped with some of the most advanced machinery in Europe.

**Verkstedvegen 19, 7125 Vanvikan, Norway**

**Tel: +47 72 83 16 11**  
**Email: marked@ctmlyng.no**

**For more information, visit us at**  
**www.ctmlyng.com**

**Thank you for choosing a product from CTM Lyng AS**

**CTM  
LYNG**

**Installation and User instructions**  
For products from serial number 1601-00001 onwards.

**External Moisture Sensor 1 m**

No. 5648536 / 6251606





The External Moisture Sensor is a security product from CTM Lyng AS.

Acts as an extension of the moisture sensor. The entire sensor detects moisture and will close the valve when moisture is detected.

The sensor is installed where moisture is expected and can be joined, but should not be joined more than 5 times / 5 metres.

Compatible with:  
• Moisture Sensor, wireless

The system is flexible, and can be expanded to accommodate different needs and security levels.

The external moisture sensor is easy to install using tape on the underside of the sensor.

Position where moisture can occur that you want to detect.



Tape on the underside.

The external moisture sensor connects to the moisture sensor at the terminal.



**TIP:** Program all the units in a system before mounting. (Master, Moisture Sensor, Motion Sensor). This will make it easier to test the equipment.

The external moisture sensor can be joined for larger zones with moisture detection, but should not be joined more than 5 times / 5 metres.

